

Standard Construction and Materials

FRAME: .063" thick (nominal) extruded aluminum, 6063-T52/T6 alloy.

BLADE: .063" thick (nominal) extruded aluminum, 6063-T52/T6 alloy.
Blades approximately 2 3/4" on centers.

LOUVER FACE: Full width sill, with blades and head contained in jambs.

SCREEN: (When indicated.)

1/2" flattened aluminum (.051" thick),

-or- 1/2" sq. mesh, intermediate double-crimped aluminum wire, .063" dia.,

-or- 18/16 mesh, .011" dia. aluminum wire, insect screen.

FINISH: Mill

Options

Finish - Baked Enamel, Kynar, Anodize

Notes

- 1/2" nominal deduction will be made to the opening size given.
- Approximate shipping weight is 3.8 lbs./sq.ft.

Louver Sizes

Min Panel	Max Single Panel
12"W x 12"H	60"W x 96"H

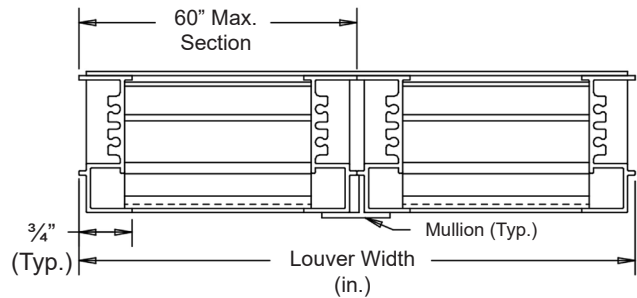
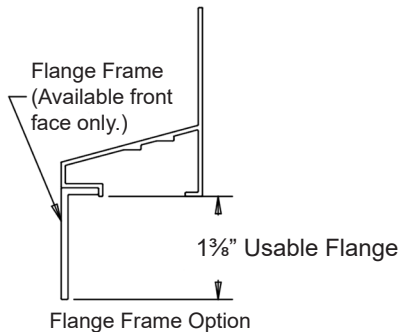
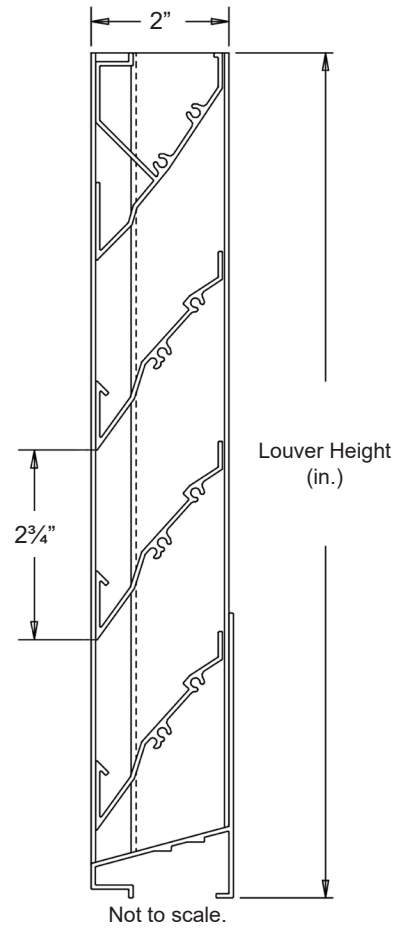

Item #	Qty	Width	Height	Width	Height	Mullion	Type	Location			Union Made
		Opening Size		Louver Size			Screens				
Arch. / Eng.:						EDR:		ECN:		Job:	
Contractor:											
Project:						Date:		DWN:		DWG:	

In the interest of product development, CESCO Products reserves the right to make changes without notice.



450 Riverside Dr • Wyalusing PA, 18853
Phone: 570-746-1888 • Fax: 570-746-9286
www.cescoproducts.com

Performance Data

Pressure Drop: .12 in. w.g. at 1000 fpm (intake)
 Free Area: 7.23 sq.ft. = 45% for 48"W x 48"H sample tested in accordance with AMCA Standard 500-L.
 Beginning Point of Water Penetration: 901 fpm

Ratings do not include effects of a screen.

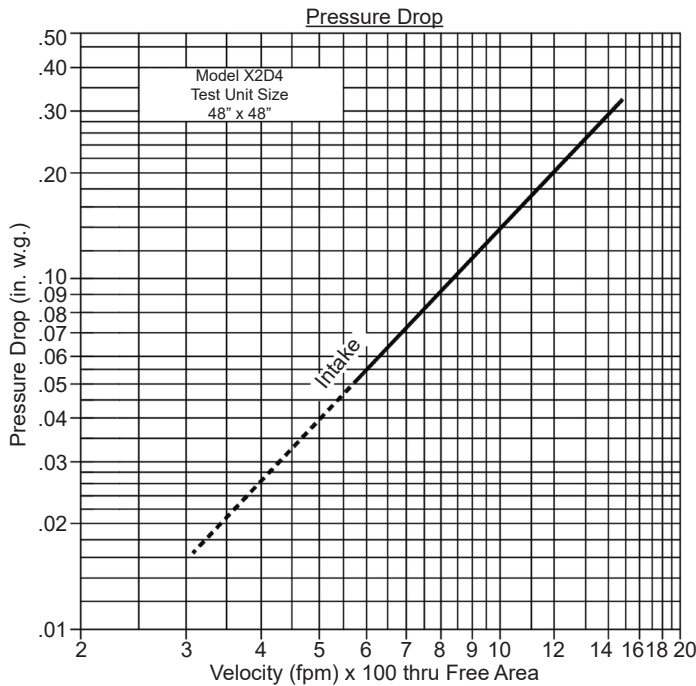

Intake air converted to standard air density.
 Tested to AMCA Standard 500-L, Figure 5.5.

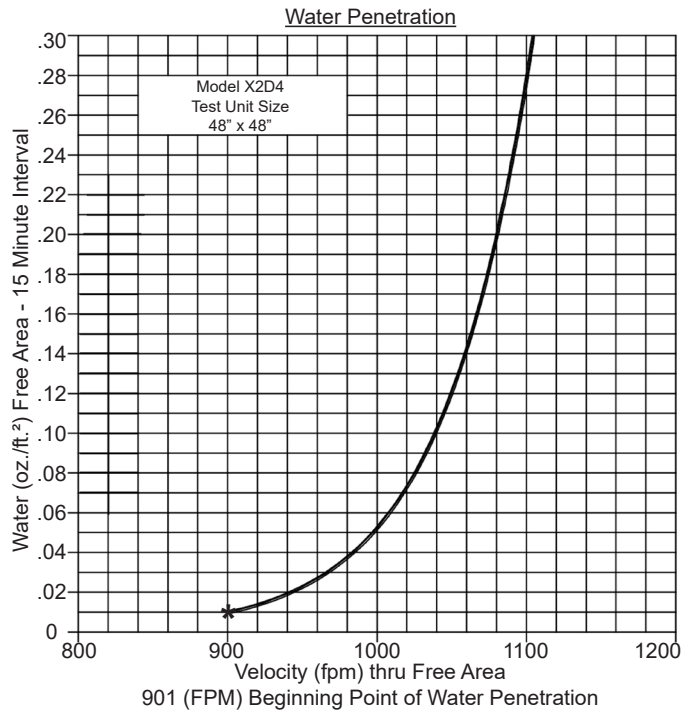

Free Area (sq.ft.)

		Width (in.)								
		12"	18"	24"	30"	36"	42"	48"	54"	60"
Height (in.)	12"	.28	.44	.60	.76	.92	1.08	1.24	1.40	1.56
	24"	.78	1.23	1.69	2.14	2.59	3.04	3.49	3.94	4.39
	36"	1.19	1.87	2.55	3.23	3.91	4.60	5.28	5.96	6.64
	48"	1.63	2.56	3.50	4.43	5.37	6.30	7.23	8.17	9.11
	60"	2.05	3.23	4.41	5.59	6.77	7.95	9.14	10.32	11.50
	72"	2.45	3.86	5.27	6.68	8.09	9.50	10.91	12.32	13.73
	84"	2.94	4.63	6.32	8.01	9.70	11.39	13.08	14.77	16.46
	96"	3.36	5.29	7.22	9.15	11.08	13.00	14.93	16.86	18.79



Cesco Products certifies that the Model X2D4 shown herein is licensed to bear the AMCA Seal. The ratings shown are based on tests and procedures performed in accordance with AMCA Publication 511 and comply with the requirements of the AMCA Certified Ratings Program. The AMCA Certified Ratings Seal applies to Air Performance and Water Penetration ratings only.